

# Point

A collection of reception counters characterised by:

**01/** High modularity. **02/** Wood and metal shelves. **03/** Speak-through central modules and end-side elements, height 73.6 cm. **04/** Corner module. **05/** Side extensions. **06/** Cable and wiring trays and fittings. **07/** Optional LED light under the shelf.

**08/** Two-colour combination for shelves and structural elements. **09/** 2 wood finishes, 3 plain colours. **10/** 3 wood finishes and 3 plain colours for the wooden shelves. **11/** 9 finishes available for metal shelves.

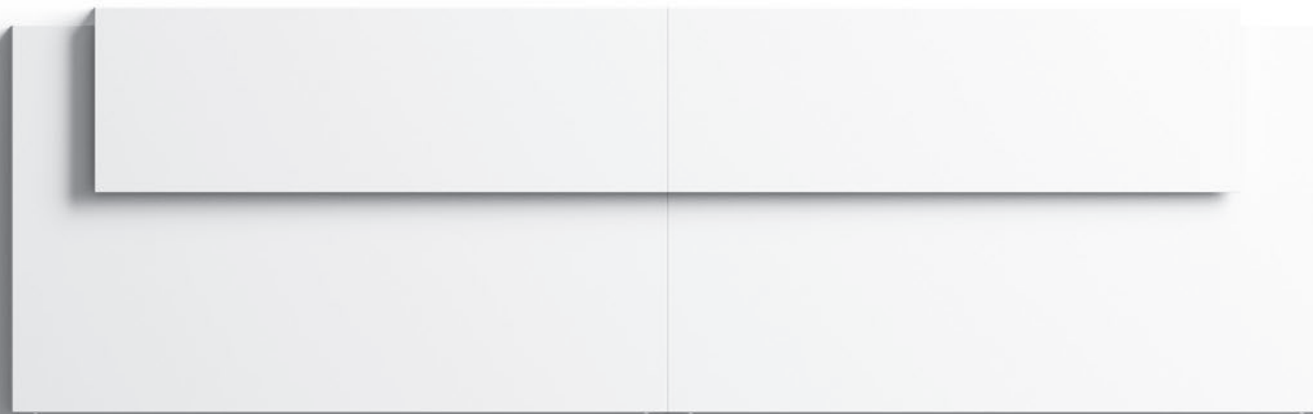





**Point è una reception ispirata a criteri di rigore formale che si articola in moduli variamente aggregabili tra loro. La semplicità compositiva e lo stile minimale generano infinite composizioni, con forme e dimensioni differenti, adattabili in ogni contesto.**

The Point reception desk is inspired to formal rigour criteria declined in versatile modules that can be combined together. The simplicity in the composition and its minimal style generate infinite combinations, with different shapes and sizes, that can be adapted to any context.

Point est un comptoir inspiré aux critères de rigueur formelle articulés dans de modules qui peuvent être différemment combinés. La simplicité de la composition et son style minimaliste permettent de créer des compositions infinies, avec différentes formes et tailles, adaptables dans tous les contextes.

→ Fianco strutturale che chiude lateralmente ogni modulo.  
Side structural element that literally closes each module.  
Côté structurel qui ferme chaque module latéralement.



cod. 03







**I moduli più semplici e di dimensioni ridotte garantiscono le stesse dotazioni e funzionalità delle composizioni più articolate. I piani di lavoro, differenti per ospiti ed operatori, si distinguono chiaramente per l'altezza da terra.**

The simplest and the smallest modules provide the same features and functionality as the most complex compositions. Different worktops for guests and operators, clearly distinguishable by their height.

Les modules les plus simples et les plus petits offrent les mêmes caractéristiques et fonctionnalités de compositions les plus articulées. Les plans de travail, différents pour les visiteurs et les opérateurs, se distinguent clairement par leur hauteur par rapport au sol.

cod. 63

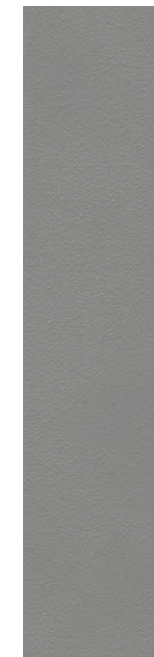

cod. 38



cod. SG 01



→ Piano di ricevimento per ospiti disabili.  
Reception worktop for disabled guests.  
Plan d'accueil pour personnes à mobilité réduite.





←  
Composizione  
lineare per  
relatori in sale  
conferenze o  
formazione.

Linear composition  
for speakers in  
conference or  
training rooms.

Composition  
linéaire pour  
les intervenants  
dans les salles  
de conférence  
ou de formation.

**La linearità dei frontali viene articolata dalle mensole metalliche, proposte in nove colori e dotate di led opzionali. Il bancone di ricevimento, nella sua semplicità, permette di creare effetti sempre diversi sia in termini cromatici che compositivi.**

The linearity of fronts panels is highlighted by the metal shelves, available in nine colours and fitted with optional LEDs. The reception counter, in its simplicity, allows to create different effects, in terms of colour and composition.

La linéarité des panneaux frontaux est définie par les étagères en métal, disponibles en neuf couleurs et équipées de LED en option. Le système, dans sa simplicité, permet de créer différents effets en termes de couleur et de composition.

cod.CL 01

cod.68



→  
Mensole lineari in  
acciaio verniciato  
in nove colori.  
Linear shelves in  
painted steel,  
available in nine  
colours.  
Étagères linéaires  
en acier peint en  
neuf couleurs.





**L'effetto cromatico e materico delle mensole metalliche valorizza il bancone di ricevimento evolvendo la linearità originaria del progetto.**

The chromatic and material effect of metal shelves adds value to the reception counter through the evolution of the original linearity of this project.

L'effet chromatique et des matériaux des étagères en métal valorise le comptoir d'accueil en soulignant l'évolution de la linéarité originale du projet.



cod. NR 03

→ Il ridotto spessore della lamiera enfatizza il pannello strutturale in legno.

The reduced thickness of the metal sheet highlights the structural wooden panel.

L'épaisseur réduite de la tôle souligne le panneau structurel en bois.



cod. CP 01



cod. VR 01

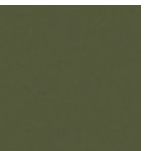



**Reception**  
Reception | Réception

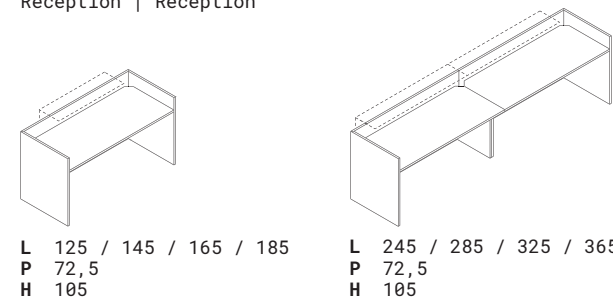

L 125 / 145 / 165 / 185  
P 72,5  
H 105

L 245 / 285 / 325 / 365  
P 72,5  
H 105

**Moduli**  
Modules | Modules

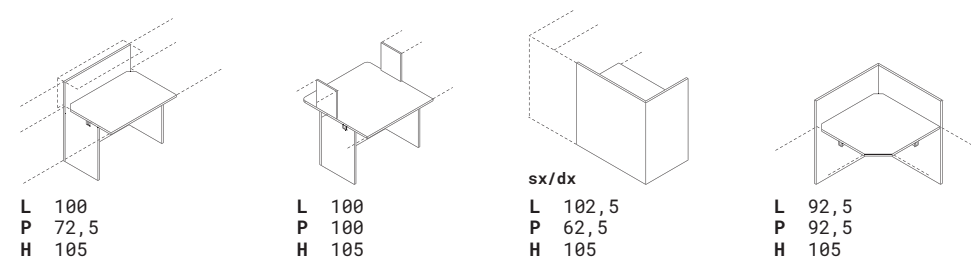

L 100  
P 72,5  
H 105

L 100  
P 100  
H 105

sx/dx  
L 102,5  
P 62,5  
H 105

L 92,5  
P 92,5  
H 105

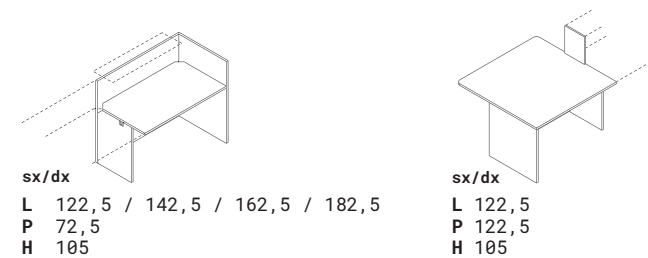

sx/dx  
L 122,5 / 142,5 / 162,5 / 182,5  
P 72,5  
H 105

sx/dx  
L 122,5  
P 122,5  
H 105

**Mensole**  
Shelves | Etageres

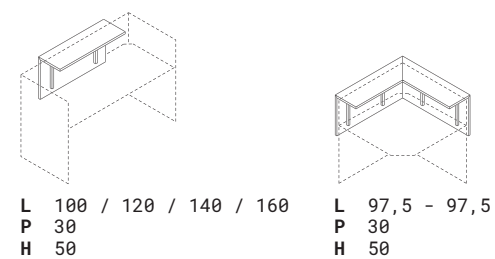

L 100 / 120 / 140 / 160  
P 30  
H 50

L 97,5 - 97,5  
P 30  
H 50

**Cattedre**  
Conference desks | Bureaux conference

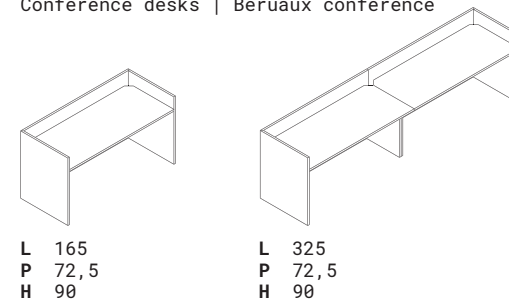

L 165  
P 72,5  
H 90

L 325  
P 72,5  
H 90



# CARTELLA COLORI

colours samples card



COD. 03  
ROVERE | OAK



COD. 38  
GRIGIO | GREY

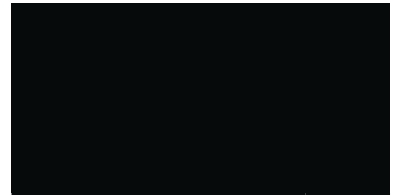

COD. 51  
NERO | BLACK



COD. 07  
NOCE CLASSICO | CLASSIC WALNUT



COD. 44  
STONE GREY | STONE GREY



COD. 63  
PIOPPO MORO | DARK POPLAR

○ = MELAMINICO | MELAMINE

○ = MELAMINICO | MELAMINE

MENSOLE IN METALLO  
metal shelves

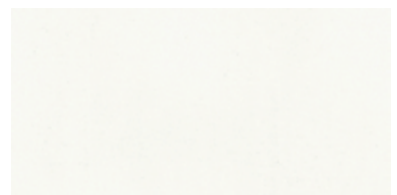

COD. 68  
BIANCO | WHITE

COLORI STANDARD  
standard colours

COLORI PASTELLO  
pastel colours



COD. AR 02  
ARGENTO | SILVER



COD. VR 01  
MUSCHIO | MOSS GREEN

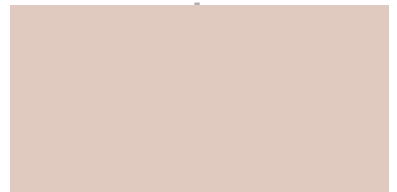

COD. CP 01 (Pantone 4755 C)  
CIPRIA | POWDER PINK

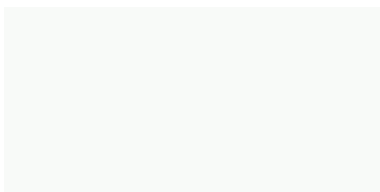

COD. BI 02 (RAL 9016)  
BIANCO | WHITE

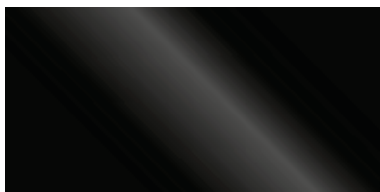

COD. NR 03  
NERO (OPACO) | (MATT) BLACK

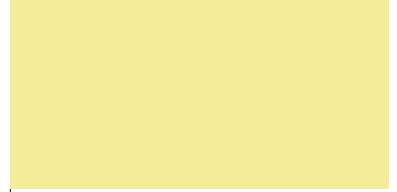

COD. GL 01 (Pantone 600 C)  
GIALLO | YELLOW



COD. SG 01  
STONE GREY | STONE GREY

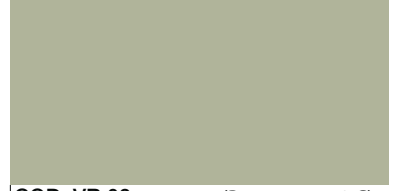

COD. VR 02 (Pantone 4178 C)  
VERDE | GREEN



COD. CL 01 (Pantone 545 C)  
CELESTE | LIGHT BLUE

- Colori essenze legno, vetri e metalli fotografati sono indicativi per motivi di stampa
- Woods, glasses and metals colours shown in the pictures are indicative for printing reasons



# ESEMPI DI COMPONENTABILITA'

examples of compositions

## RECEPTION LINEARE SINGOLA single linear reception

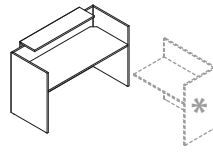

**ART.013+045**

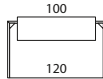

**ART.014+045**

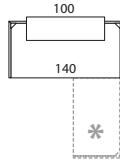

**ART.019+046**

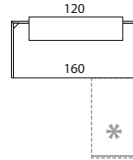

**ART.020+047**

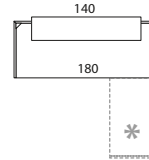

- VISTE IN PIANTA -  
- Top view -

\* = POSSIBILITA' DI UTILIZZO ALLUNGO RECEPTION DX O SX  
= Possibility to use the right or left extension reception

## RECEPTION LINEARE DOPPIA double linear reception

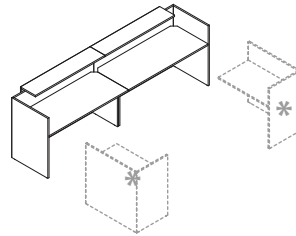

**1 ART.022 + 2 ART.045**

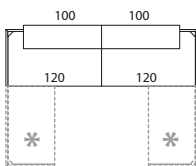

**1 ART.023 + 2 ART.046**

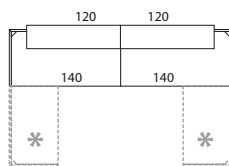

**1 ART.024 + 2 ART.047**

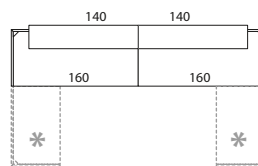

**1 ART.025 + 2 ART.048**

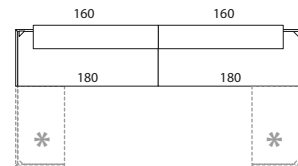

## RECEPTION LINEARE CON MODULO PROLUNGA CENTRALE linear reception with central modulo

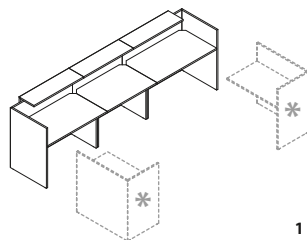

**1 ART.022 + 1 ART.027 + 3 ART.045**

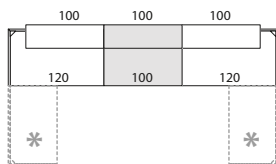

**1 ART.023 + 1 ART.027 + 1 ART.045 + 2 ART.046**

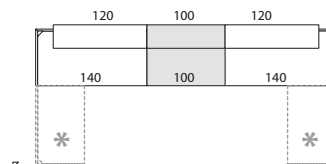

**1 ART.024 + 1 ART.027 + 1 ART.045 + 2 ART.047**

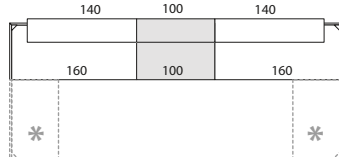

**1 ART.025 + 1 ART.027 + 1 ART.045 + 2 ART.048**

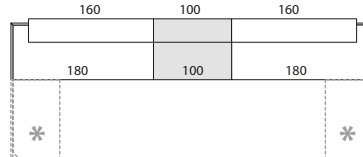

# ESEMPI DI COMPONENTABILITA'

examples of compositions

RECEPTION TERMINALI  
CON ANGOLO, PROLUNGA CENTRALE E MODULI CONVERSAZIONE  
terminal reception with corner, central module and conversation modules

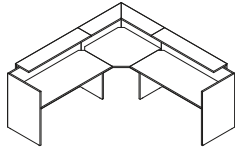

ART.054-055-056-057+  
ART.045-046-047-048+  
LED ART.060-061-062-063

ART.049+  
ART.066+  
LED ART.064

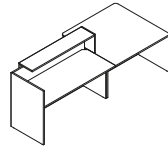
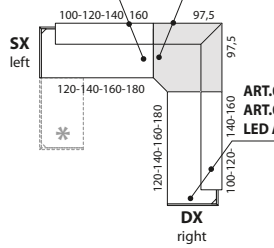

ART.054-055-056-057+  
ART.045-046-047-048+  
LED ART.060-061-062-063

ART.058-069

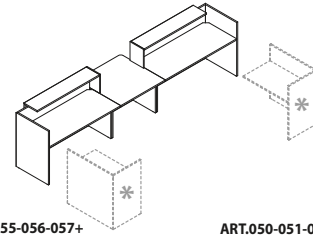
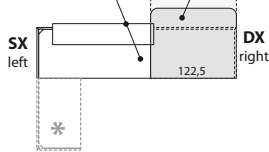

ART.054-055-056-057+  
ART.045-046-047-048+  
LED ART.060-061-062-063

ART.028

ART.050-051-052-053+  
ART.045-046-047-048+  
LED ART.060-061-062-063

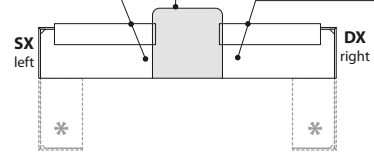

\* = SU TUTTE LE RECEPTION TERMINALI C'E' POSSIBILITA' DI UTILIZZO ALLUNGO RECEPTION DX O SX  
= Possibility to use the right or left extension with all terminal reception

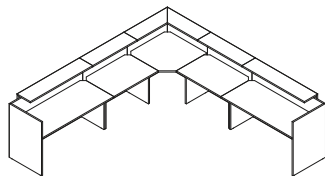

ART.054-055-056-057+  
ART.045-046-047-048+  
LED ART.060-061-062-063

ART.027+  
ART.045+  
LED ART.060

ART.049+  
ART.066+  
LED ART.064

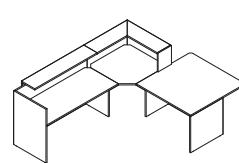
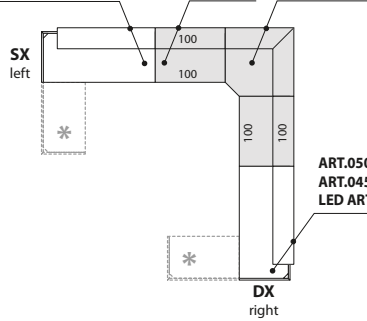

ART.054-055-056-057+  
ART.045-046-047-048+  
LED ART.060-061-062-063

ART.049+  
ART.066+  
LED ART.064

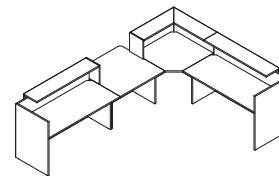
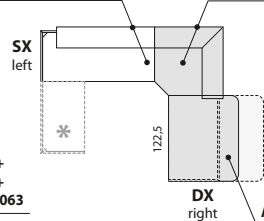

ART.054-055-056-057+  
ART.045-046-047-048+  
LED ART.060-061-062-063

ART.028

ART.049+  
ART.066+  
LED ART.064

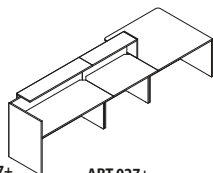
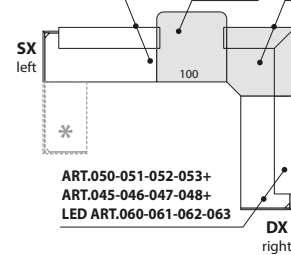

ART.054-055-056-057+  
ART.045-046-047-048+  
LED ART.060-061-062-063

ART.027+  
ART.045+  
LED ART.060

ART.058-069

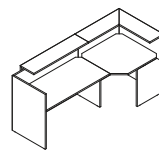
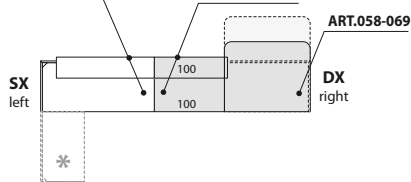

ART.054-055-056-057+  
ART.045-046-047-048+  
LED ART.060-061-062-063

ART.049+  
ART.066+  
LED ART.064

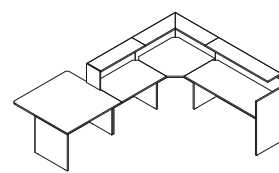
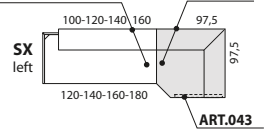

ART.059-070

ART.027+  
ART.045+  
LED ART.060

ART.049+  
ART.066+  
LED ART.064

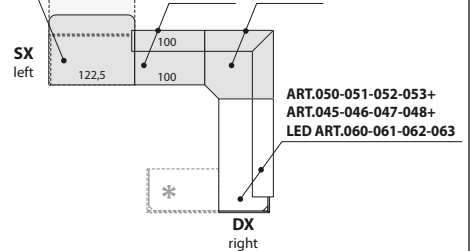

**DIMENSIONI**  
*dimensions*

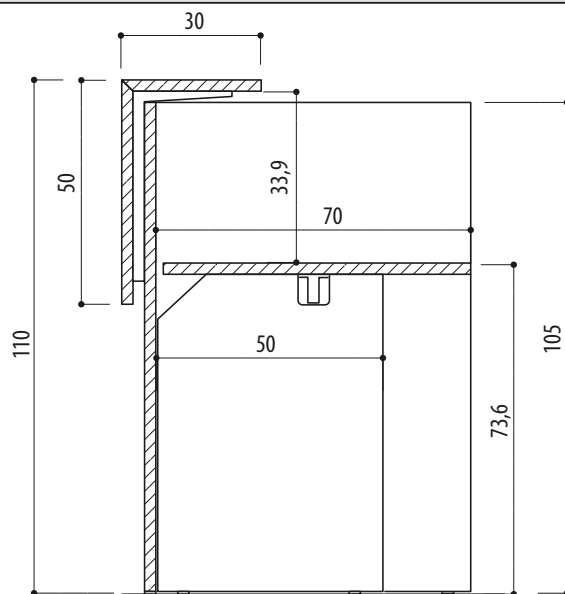

SEZIONE VERTICALE  
MODULI RECEPTION  
vertical section of  
reception modules

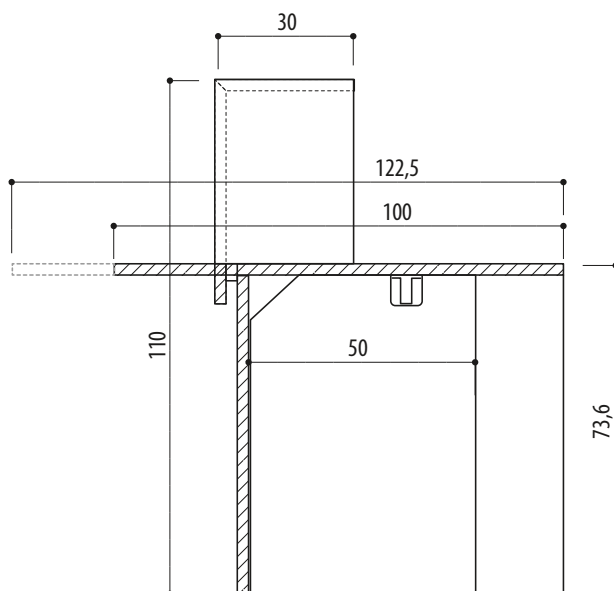

SEZIONE VERTICALE  
MODULI CONVERSAZIONE  
vertical section of  
conversation modules

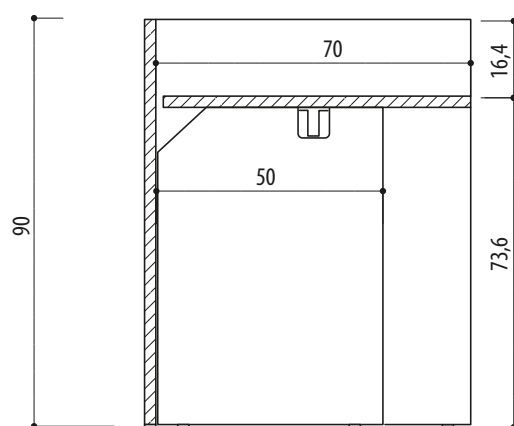

SEZIONE VERTICALE  
CATTEDRE  
vertical section of  
conference desks