

JERA ENOSI E.O.S. IULIO ELITE
DELTA **FIL ROUGE 5th ELEMENT**
OXI UP SCHERMI PIEGO CHIUDO
SEGUO SHARE CUBO PRONTO
CONTENITORI UNIVERSALI
I-MEET NICE POINT JAVA PAUSA
CONVIVIO FUNGO SEGNO
ICARO REGOLO KYOTO PODIO
LEAD JERA SCENA NEOCHAIR
TRAMA ATHENA FORMEN
GALASSIA DOLLY STAR SISTEMA
CAST CIAK PRIMA RASSEGNA
ESSAI HELLÒ OSCAR BROADWAY
F01 F02 F03 F04 F05 REGIA
VEDETTE FICTION TROUPE
ZOOM SUPEROTTO PROVINO
SELLO F01 BENCH F03 BENCH
MOVIE TRUKA JERA24 FESTIVAL
JETSET JERA22 TREND SET22
DOMUS DRIVE IN DIVO FLAGS
TRAILER WORKLAND





↑
 Semplicità e solidità strutturale leggibili nell'unione tra piano e gamba.
 Simplicity and structural strength expressed in the junction between the worktop and the legs.
 Simplicité et solidité structurelle visibles dans la jonction entre le plateau et le pied.

cod. 03

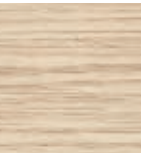

Oxi si caratterizza per la gamba a ponte sobria e sempre attuale. Con le sue soluzioni geometriche e tecniche soddisfa qualsiasi esigenza funzionale e di layout, inserendosi perfettamente in ogni ambiente grazie anche alle numerose finiture e agli accessori.

Oxi features sober and elegant bridge legs. Thanks to its geometric and technical solutions it can meet any functional and layout needs, fitting perfectly into any environment with its many finishes and accessories.

Oxi se caractérise pour la jambe à pont, sobre et toujours actuelle. Avec ses solutions géométriques et techniques, il satisfait toutes les exigences fonctionnelles et de configuration, s'intégrant parfaitement dans n'importe quel environnement grâce aux nombreuses finitions et accessoires.

→
 La sobrietà delle forme consente un perfetto abbinamento con tutti i contenitori a catalogo.
 Sober shapes create a perfect match with all the storage options included in the catalogue. La sobriété des formes permet une correspondance parfaite avec tous les rangements du catalogue.



Postazioni articolate in aggregazioni complesse. I piani sagomati sono valorizzati dalle gambe, minimali e moderne. I piccoli schermi consentono una separazione discreta. I contenitori introducono in modo nuovo il metallo e il colore.

Diversified layouts for complex aggregations. Shaped worktops are highlighted by their minimal and modern legs. Low partition screens provide unobtrusive separation. Storage units introduce metal and colour with a new approach.

Postes de travail recherchées et complexes. Les plateaux en forme sont valorisés par les pieds, minimaux et modernes. Les petits écrans offrent une séparation discrète. Les rangements introduisent le métal et la couleur d'une nouvelle façon.

cod. CP 01

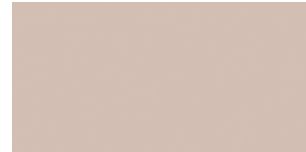

cod. 03

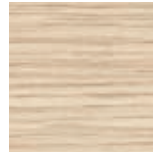

Le postazioni di lavoro, semplici o con piano sagomato, si integrano con contenitori di varia tipologia e dimensione e soddisfano le più diverse esigenze estetiche e funzionali, creando effetti compositivi sempre piacevoli.

The workstations, simple or with shaped top, are integrated with storage units of different dimensions to meet any aesthetic and functional needs, creating pleasant effects.

Les postes de travail, simples ou avec plateau en forme, s'intègrent avec rangements de différentes typologies pour répondre aux exigences esthétiques et fonctionnelles les plus diverses, tout en créant des compositions agréables.

← Gli abbinamenti si moltiplicano, le finiture legno, colori pieni e tinte pastello.

Multiple combinations with wood finishes, plain colours and pastel shades.

Les combinaisons se multiplient : finitions bois, teintes unies et tons pastel.



Scrivanie integrate con i contenitori Comby. Soluzioni progettate per ottenere superfici ampie e spazi di stoccaggio comodi e capienti. Isole funzionali che suddividono lo spazio creando postazioni di lavoro autonome ispirate a criteri fortemente operativi.

Integration of desks and Comby storage units. These solutions are designed to provide large surfaces and convenient storage room. Functional islands that divide spaces creating autonomous workstations, strongly inspired to operation.

Bureaux intégrés avec les rangements Comby. Solutions conçues pour obtenir des grandes surfaces et espaces de rangement amples et confortables. Îles fonctionnelles qui divisent l'espace, en créant des postes de travail autonomes inspiré par des critères fortement opérationnels.



cod. 38



Schienali dotati di rivestimenti fonoassorbenti, perfettamente attrezzabili con accessori porta cancelleria. Soluzioni studiate per migliorare l'operatività, soddisfare il gusto e migliorare l'acustica dell'intero spazio di lavoro.

Side panels are finished with sound-absorption materials and can receive accessories to hold stationery and small objects. Ideal solutions that improve functionality, meet aesthetics needs and increase acoustic isolation in the entire work space.

Dossiers avec revêtement insonorisant, qui peuvent être équipés avec accessoires porte papeterie. Solutions étudiées pour faciliter les opérations, satisfaire le goût et améliorer l'acoustique de l'ensemble de l'espace de travail.



cod. 68



cod. 39

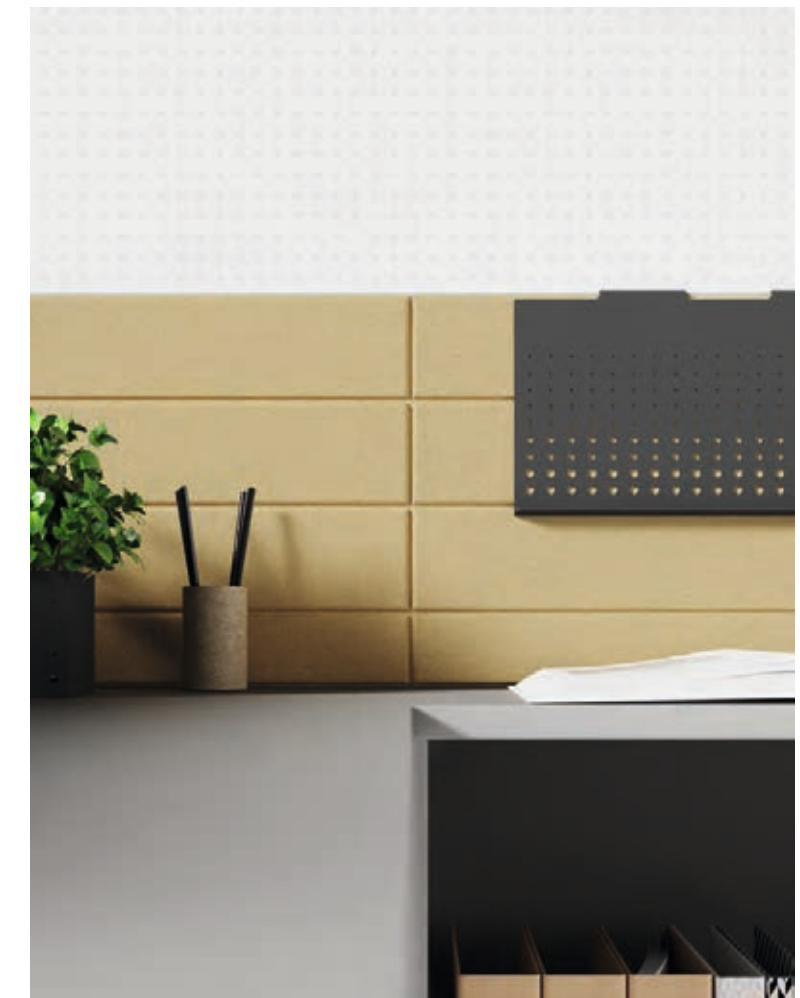
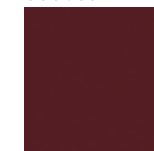



←
Tavolo riunioni
rettangolare in
versione interamente
pannellata.
Fully-panelled
rectangular meeting
table.
Tables de réunion
rectangulaire en
version avec
panneaux.

cod. 38

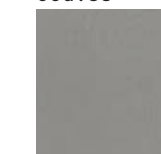

↓
Tavolo riunioni
rettangolare con gambe
metalliche a T.
Rectangular meeting
table with T-shaped
metal legs.
Tables de réunion
rectangulaire avec
pieds en T en métal.

cod. 31

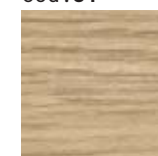

→
Cipria e Bianco creano
insieme un effetto
delicato e nuovo per
l'ufficio.

Cipria and Bianco
create together a
delicate effect, new
to the office.

Cipria et Bianco
créent, ensemble,
un nouvel effet de
délicatesse pour le
bureau.

cod. 46

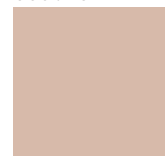

cod. CP 01



cod. 609

operative

↑
I contenitori
accolgono portaoggetti
metallici microforati
modulari.

Storage units are
fitted with modular
and micro-perforated
metal trays.

Les rangements
peuvent être équipés
avec porte-objets
modulaires en métal
micro-perforé.

**Le scrivanie, i contenitori
ed accessori creano
insieme composizioni
articolate e sempre nuove.
Ogni elemento con la sua
forma diventa parte di un
allestimento complesso e
stimolante.
Il colore bianco si pone
come sfondo su cui inserire
colori e forme diverse.**

Desks, storage units and
accessories together create
diversified and ever-new
configurations.
The shape of each element
becomes part of a more
complex and stimulating
layout.
The white background
invites to add colours and
shapes.

Les bureaux, les rangements
et les accessoires créent
ensemble des compositions
articulées et toujours
nouvelles. Chaque élément
s'intègre avec sa forme
dans un décor complexe
et stimulant. La couleur
blanche crée le fond sur
lequel insérer couleurs et
formes différentes.



La collezione permette molteplici abbinamenti di finiture, sia nelle scrivanie sia nei contenitori e crea gradevoli effetti cromatici.

This collection allows endless finishing combinations of desks and storage units to create pleasant colour effects.

La collection permet plusieurs combinaisons de finitions, dans les bureaux aussi bien que dans les rangements, en créant des agréables effets chromatiques.



Gli smart office cabinets presentano le innovative ante metalliche microforate pensate per vivacizzare l'allestimento ed introdurre colori di tendenza. L'alternanza dei materiali contribuisce a creare ambientazioni accattivanti che stimolano l'operatività.

Smart office cabinets are fitted with innovative micro-perforated metal doors, conceived to cheer up the combination with trendy colours. Alternating materials contribute to create attractive environments that encourage activity.

Les « smart cabinets » sont caractérisé par les modernes portes en métal micro-perforé, conçues pour animer le décor et introduire des couleurs tendance. La combinaison des matériaux contribue à créer des environnements charmants qui stimulent l'activité.



Semplici scrivanie attrezzate con contenitori a giorno o con ante metalliche a contrasto di colore. Composizioni sobrie e funzionali progettate per ottimizzare lo spazio e creare ordine ed efficienza.

Essential desks with matching storage modules, open or with metal doors in contrasting colours. Sober and functional combinations designed to optimise space and create order and efficiency.

Des simples bureaux équipés avec rangements ouverts ou avec portes en métal contraste de couleurs. Compositions sobres et fonctionnels, conçues pour optimiser l'espace et créer ordre et efficacité.

cod. 03

cod. AV 02

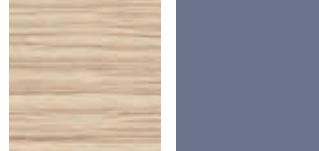

cod. 39

cod. RS 02

cod. 68



→
Le gambe metalliche a T, riducendo gli ingombri, favoriscono l'operatività.

T-shaped metal legs reduce the overall dimensions and facilitate operation.

Les pieds en métal en forme de T réduisent l'encombrement et sont plus fonctionnels.

Scrivanie operative
Operative desks | Bureaux operatifs

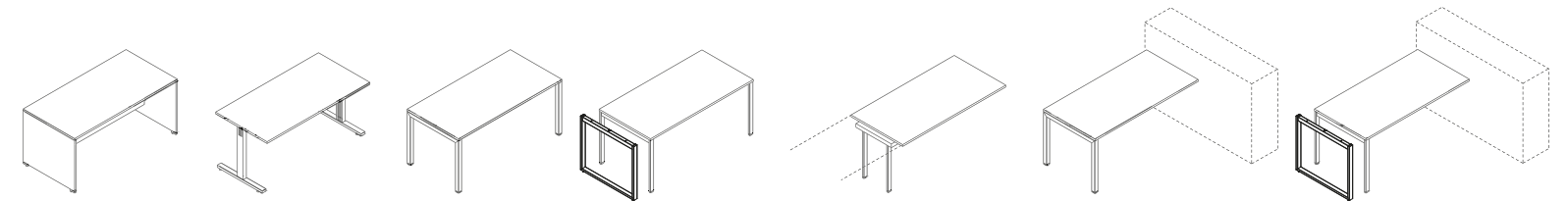

L 80 / 100 / 120 / 140 / 160 / 180
P 70 / 80
H 73,6

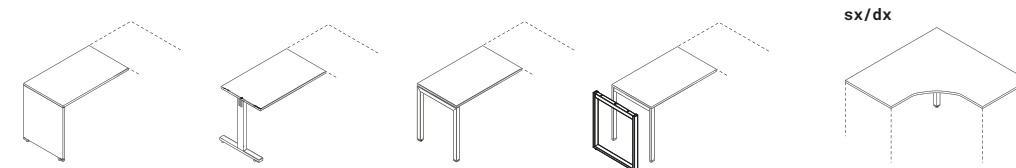

L 80 / 100
P 60
H 73,6

L 140 x 140
P 70
H 73,6

Bench
Bench | Bench

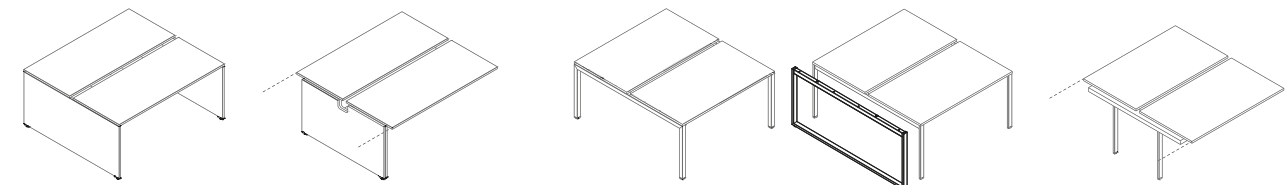

L 120 / 140 / 160 / 180
P 145,2
H 73,6

L 120 / 140 / 160 / 180
P 145,2 / 165,2
H 73,6

Tavoli riunione
Meeting tables | Tables de réunion

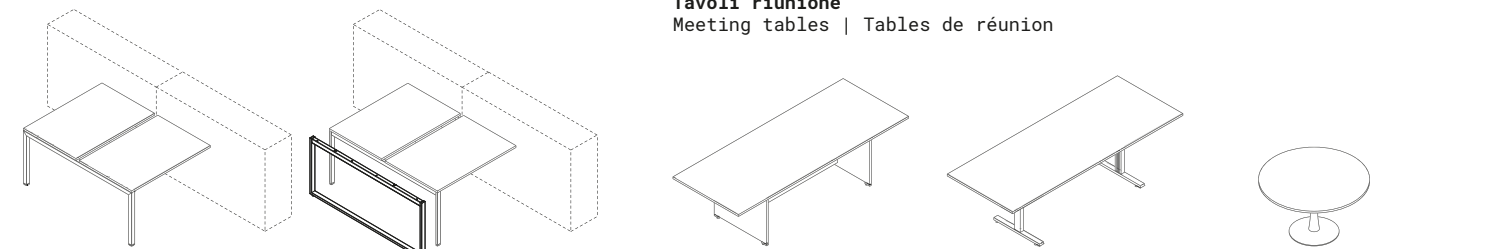

L 210 / 260
P 100
H 73,6

Ø 80 / 100 / 120
H 71,8

Comby
Comby | Comby

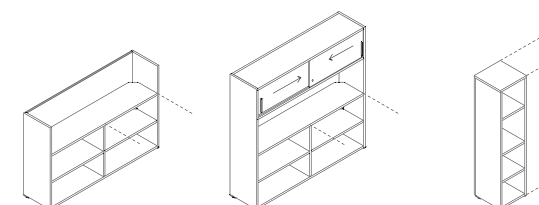

L 165
P 40
H1 109,3 / H2 160

L 40
P 40
H 160

MELAMINICI
melamines



COD. 03
ROVERE | OAK



COD. 38
GRIGIO | GREY

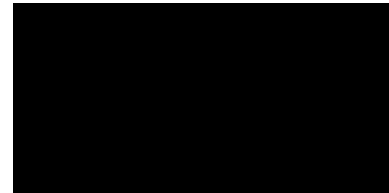

COD. 59
NERO | BLACK



COD. 07
NOCE CLASSICO | CLASSIC WALNUT

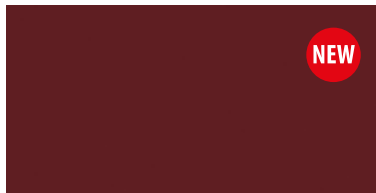

COD. 39
ROSSO GRANATO | GRANADE RED



COD. 63
PIOPPO MORO | DARK POPLAR



COD. 09
ROVERE NATURALE | NATURAL OAK



COD. 40
SALVIA | SAGE GREEN

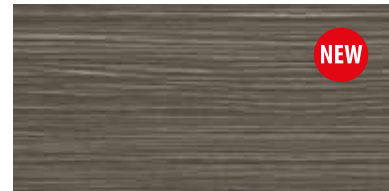

COD. 64
PIOPPO LIGHT | LIGHT POPLAR

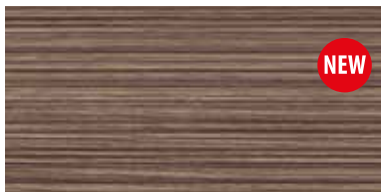

COD. 13
NOCE MODERNO | MODERN WALNUT



COD. 41
BLU NEBBIA | MISTY BLUE

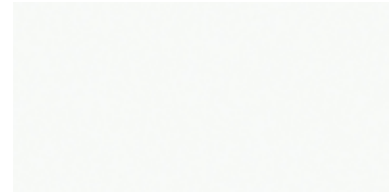

COD. 68
BIANCO | WHITE



COD. 20
MUSCHIO | MOSS GREEN



COD. 44
STONE GREY | STONE GREY



COD. 31
ROVERE NIAGARA | NIAGARA OAK

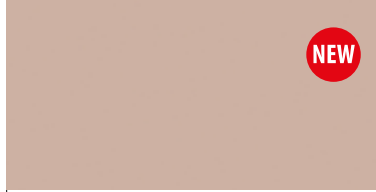

COD. 46
ROSA ANTICO | ANTIQUE PINK

STRUTTURE METALLICHE CON GAMBE A "T"
METALLIC STRUCTURE WITH "T" LEGS



COD. AR 02
ARGENTO | SILVER

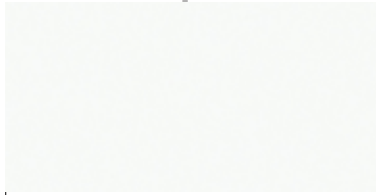

COD. BI 02 (RAL 9016)
BIANCO | WHITE



COD. SG 01
STONE GREY | STONE GREY

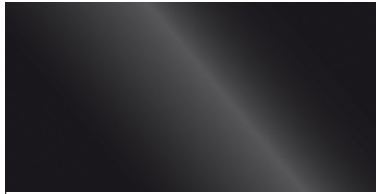

COD. NR 03
NERO (OPACO) | (MATT) BLACK

STRUTTURE METALLICHE GAMBE A PONTE E ACCESSORI
METALLIC STRUCTURE WITH BRIDGE LEGS AND ACCESSORIES



COD. AR 02
ARGENTO | SILVER

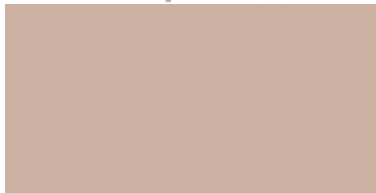

COD. CP 01
CIPRIA | POWDER PINK



COD. RS 02 (RAL 3005)
ROSSO GRANATO | GRANADE RED

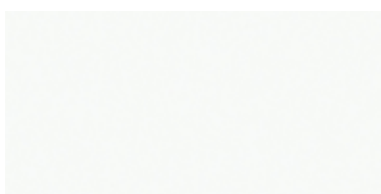

COD. BI 02 (RAL 9016)
BIANCO | WHITE



COD. VR 02
VERDE | GREEN

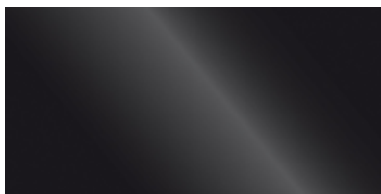

COD. NR 03
NERO (OPACO) | (MATT) BLACK



COD. AV 02
AVIO | NAVY BLUE



COD. SG 01
STONE GREY | STONE GREY



COD. VR 01
MUSCHIO | MOSS GREEN

- Colori essenze legno, vetri e metalli fotografati sono indicativi per motivi di stampa
- Woods, glasses and metals colours shown in the pictures are indicative for printing reasons

TIPOLOGIE SCRIVANIE

typology desks

OXI_P

Scrivanie e bench pannellati
Desks and bench with panel base

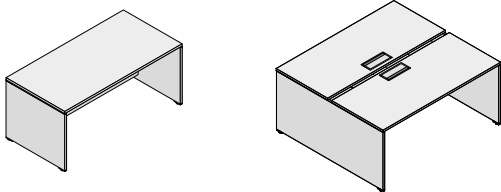

OXI_T

Scrivanie con gambe a "T"
Desks with "T" legs

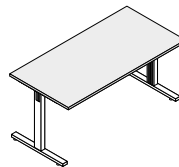

OXI_Q

Scrivanie e bench gambe a ponte sezione quadrata
Desks and bench with bridge legs with squared section

OXI_R

Scrivanie e bench gambe a ponte sezione rettangolare
Desks and bench with bridge legs with rectangular section

OXI_L

Scrivanie e bench gambe a loop
Desks and bench with loop legs

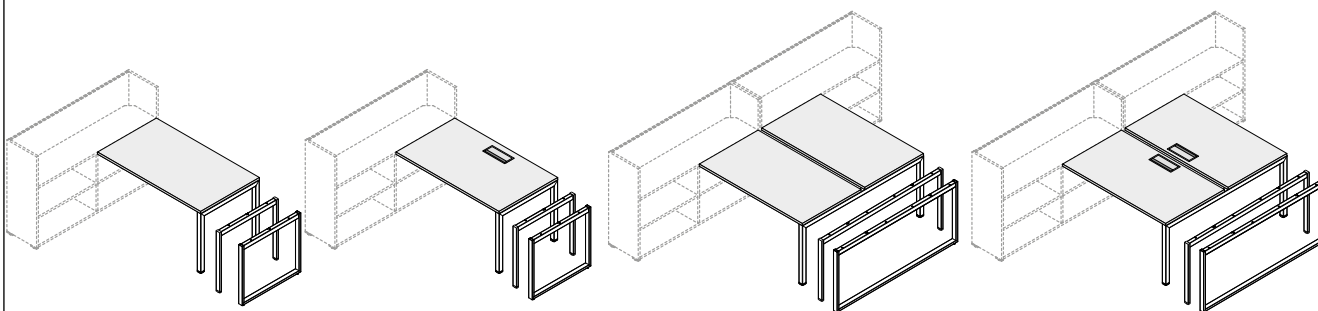
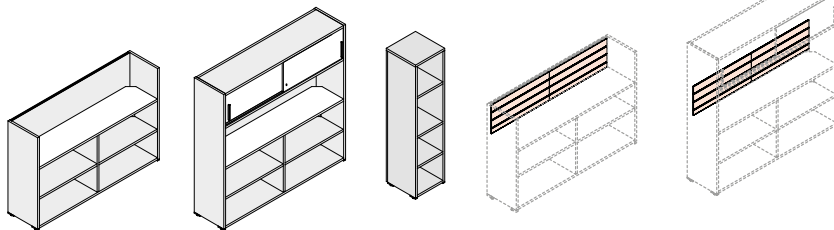
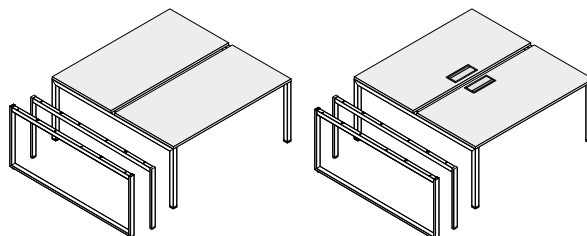
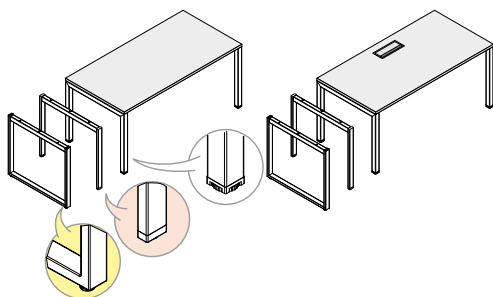

ELEMENTI COMUNI_shared elements

- SCHIENE SCRIVANIE
- VASCHETTE PORTACAVI
- COPERTURE CENTRALI
- PIANI SCRIVANIE E WORKSTATION
- PENISOLA E ANGOLO DI RACCORDO
- PARETINE
- ACCESSORI PER COMBY E PARETINE
- TAVOLI RIUNIONE
- modesty panels
- cable trays
- central covers
- desk tops and workstation tops
- terminal and joining segment
- partition panels
- accessories for comby and partition panels
- meeting tables

DIMENSIONI SCRIVANIE E VENATURE

dimensions of desks and wood veinings

ALLUNGHI EXTENSION

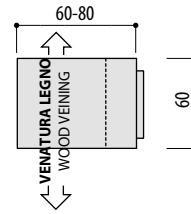
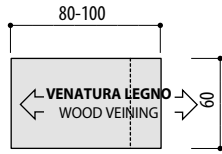

SCRIVANIE DESKS

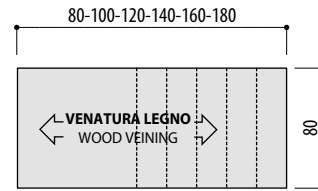
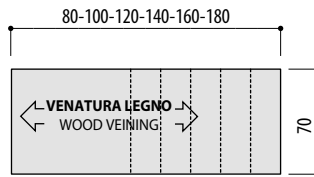
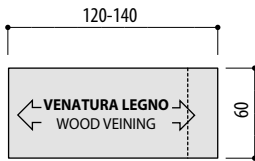

BENCH

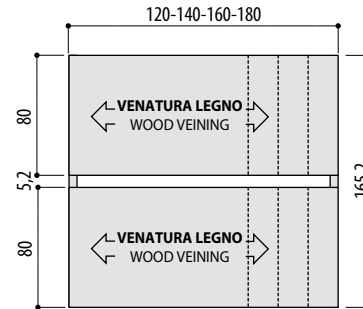
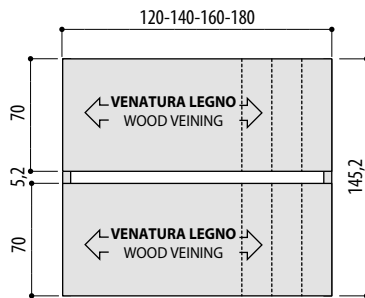

WORKSTATION SIMMETRICA SYMMETRICAL WORKSTATION

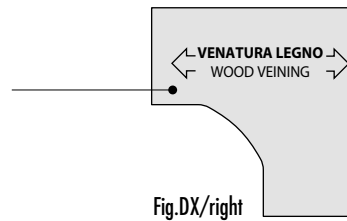
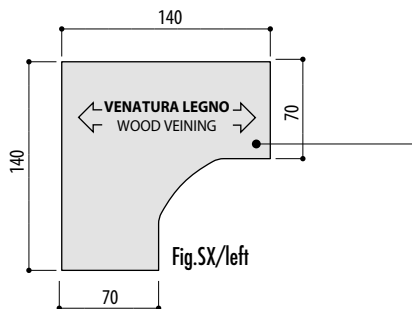

SCHEMA BASAMENTI SOTTOPIANO E PARETINE UTILIZZABILI PER SUPPORTARE PIANI LINEARI
scheme of undertop base and partition walls used as support of linear tops

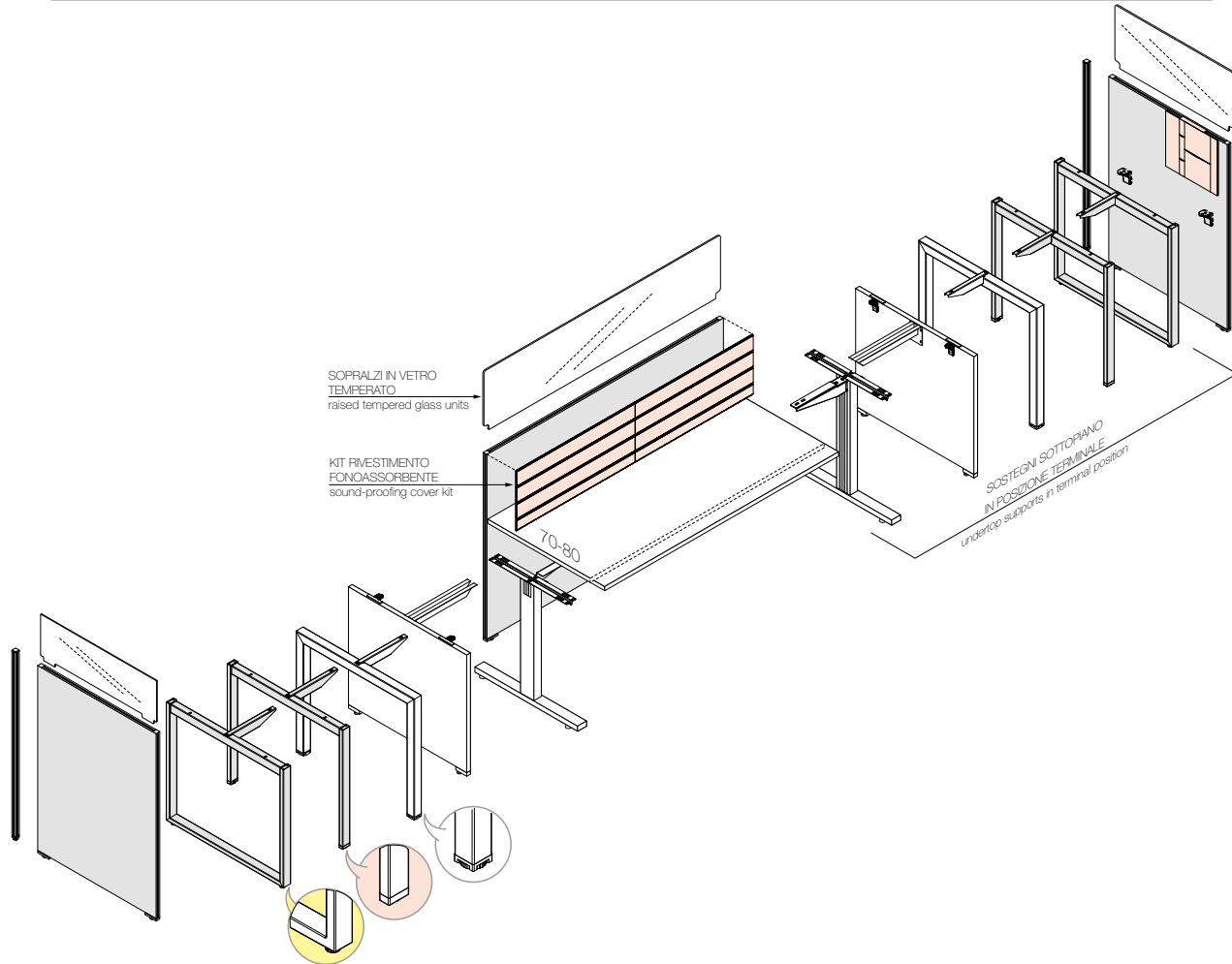

SCHEMA DI UTILIZZO SOSTEGNI SOTTOPIANO
scheme of using for undertop supports

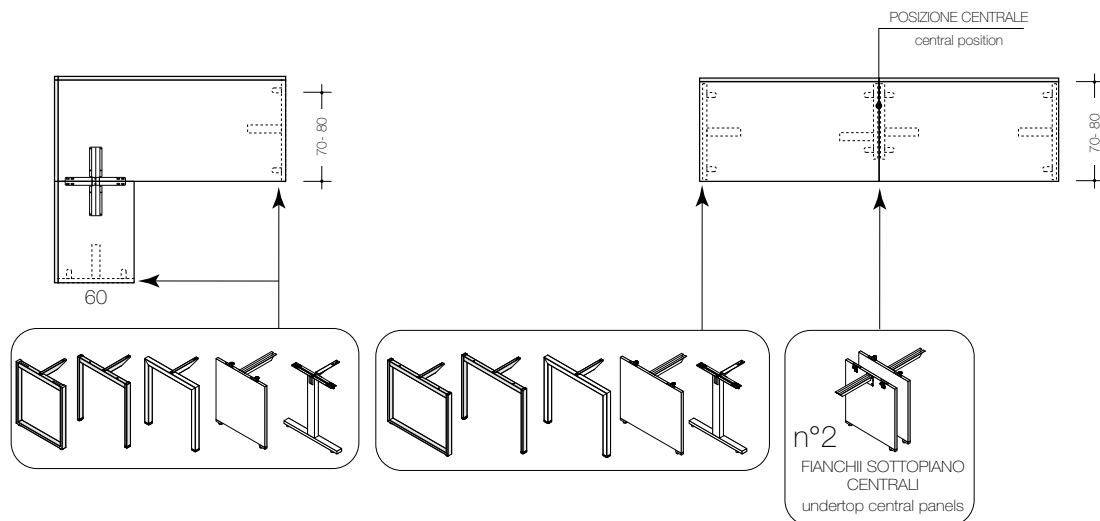

- INFORMAZIONI TECNICHE -

-Technical information-

SCHEMA BASAMENTI SOTTOPIANO E PARETINE UTILIZZABILI PER SUPPORTARE PIANI WORKSTATION

scheme of undertop base and partition walls used as support of workstation tops

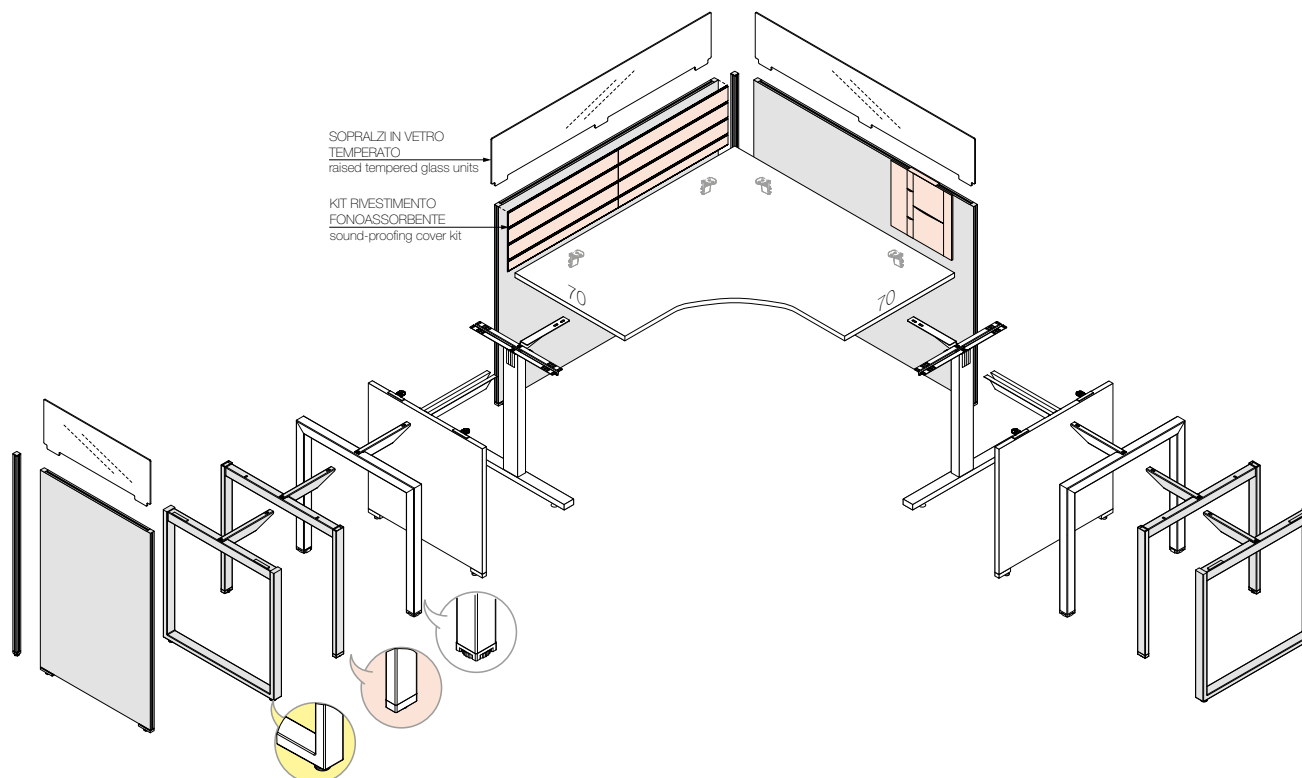

SCHEMA DI UTILIZZO SOSTEGNI SOTTOPIANO

scheme of using for undertop supports

