

Concerto

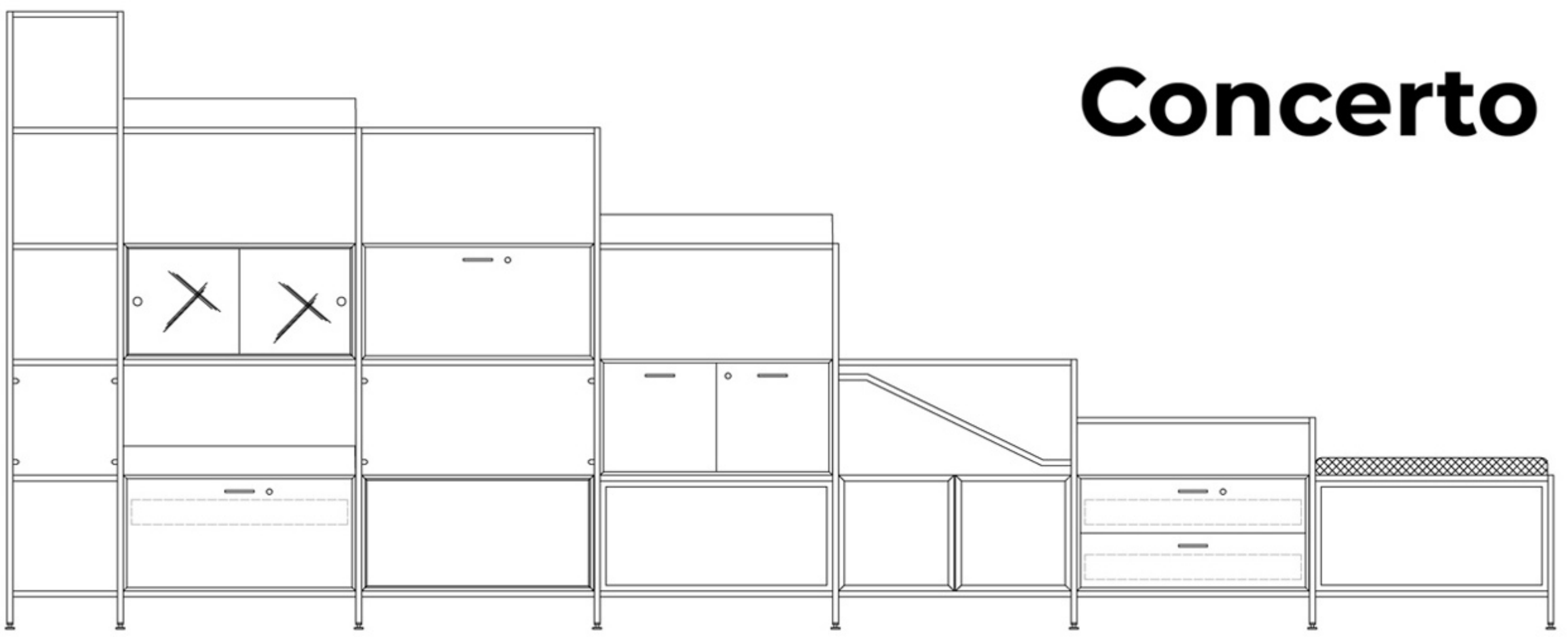

Technische Informationen

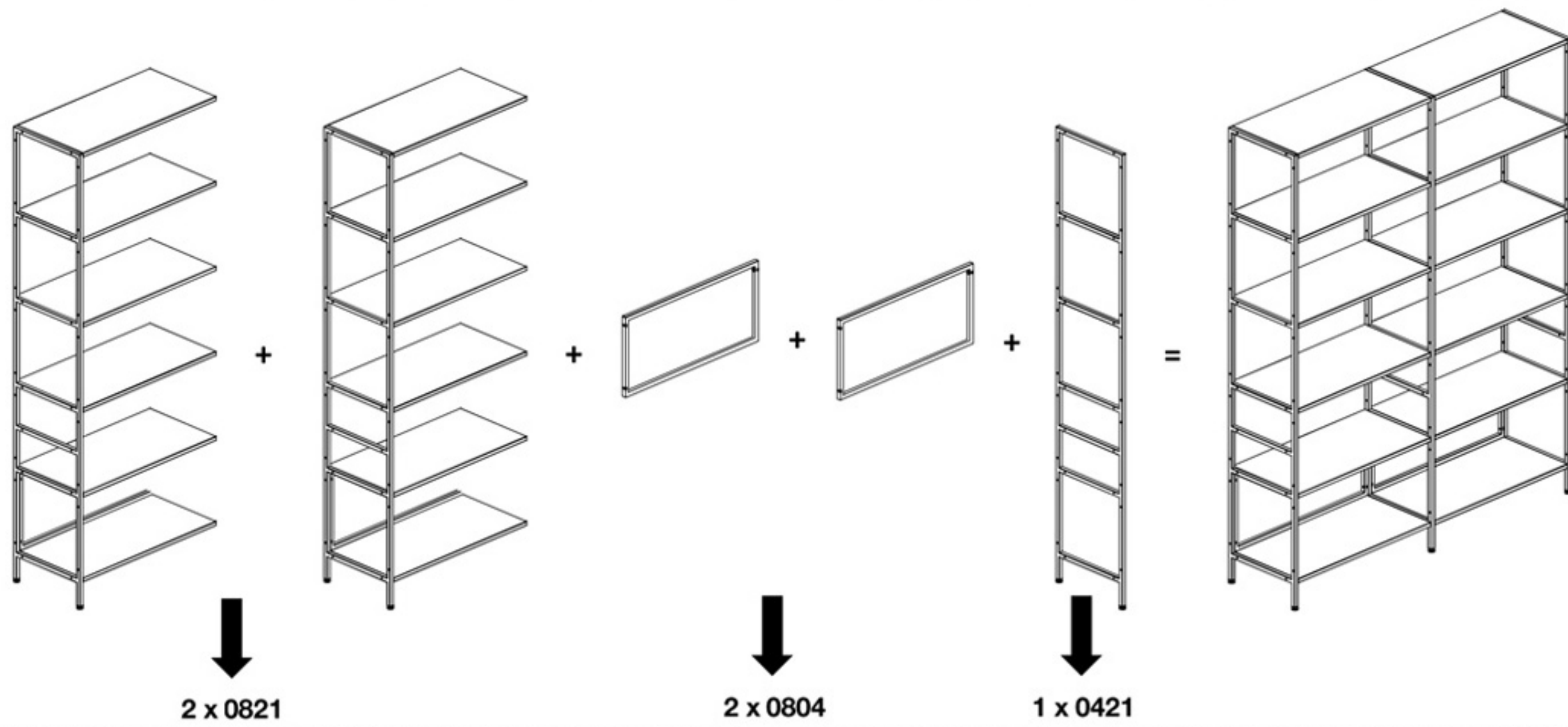

Tische

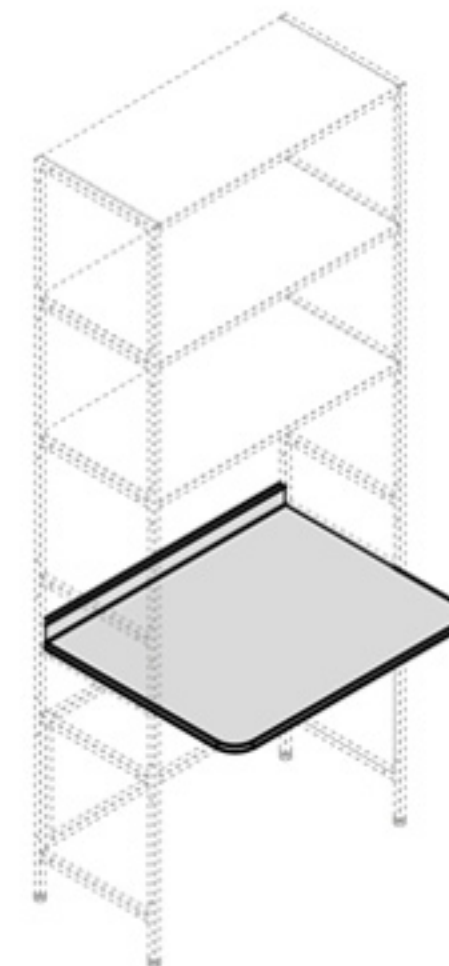

Schreibplatte

W cm	D cm	H cm
80	63,2	7

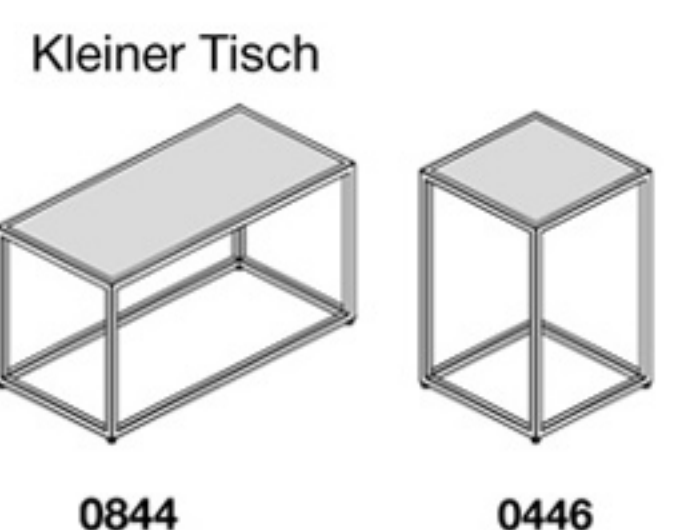
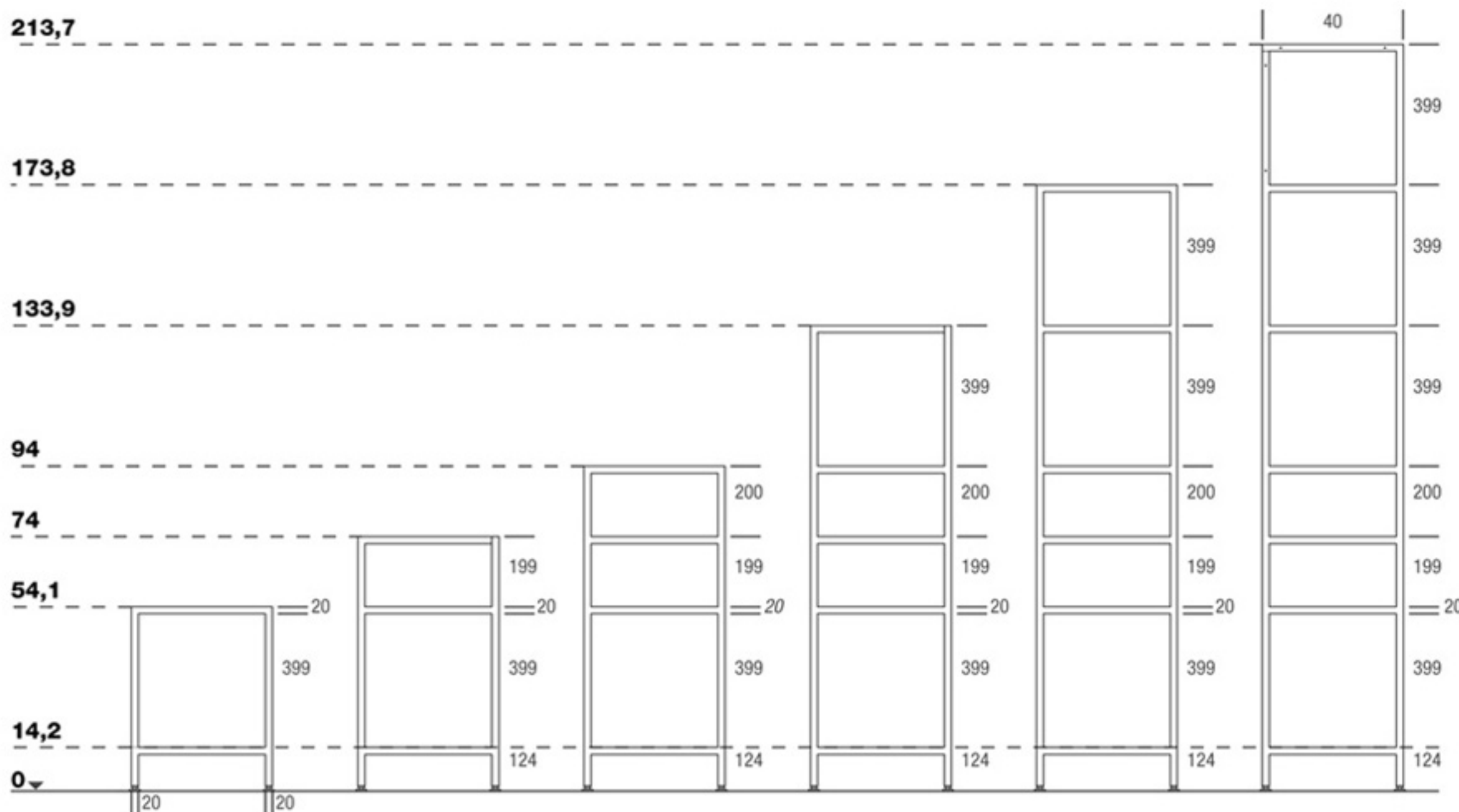

84,4	40	45,4
40	40	57

Concerto *B-sound*

Schallschluckpaneele - Fixierung mit Magneten

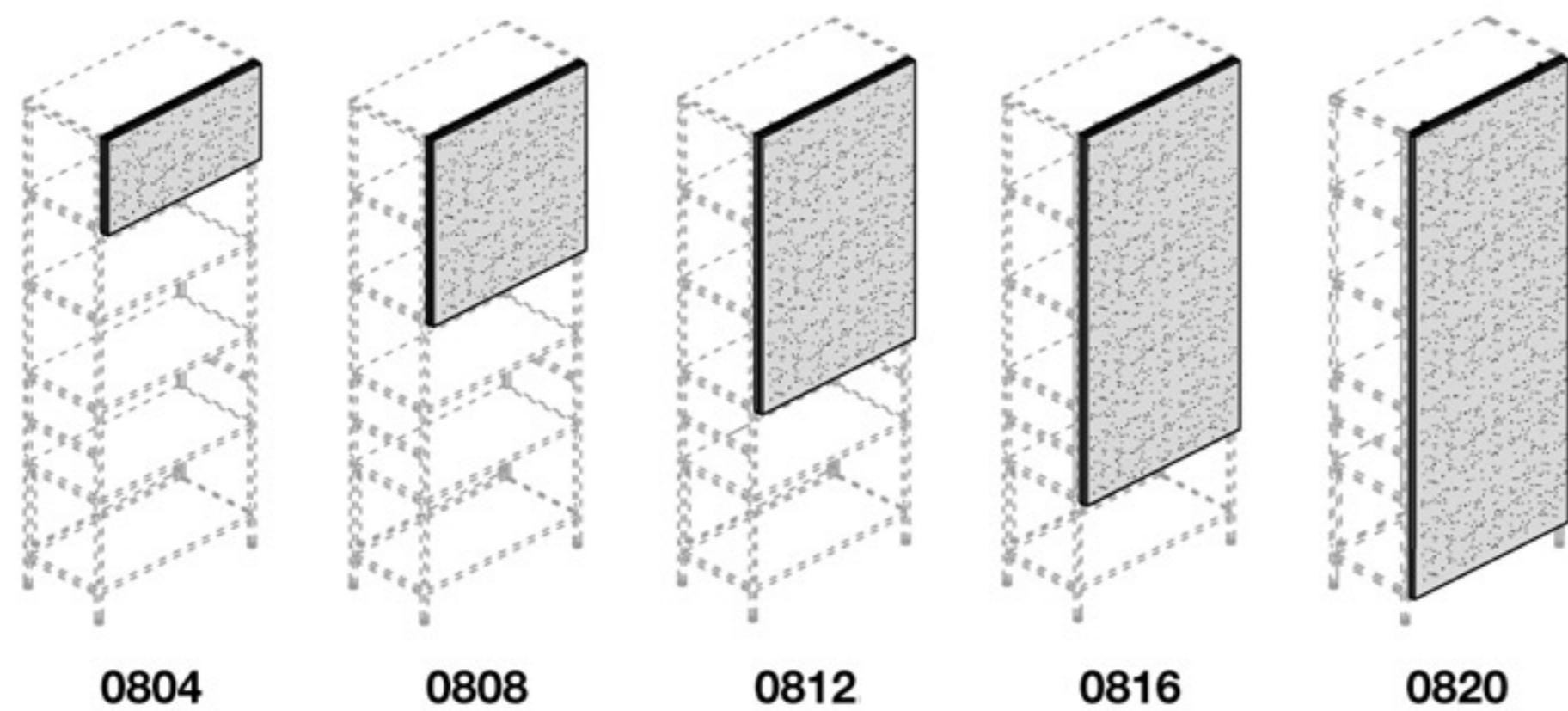

W cm	D cm	H cm
81,8	4,2	39,7
81,8	4,2	79,6
81,8	4,2	119,5
81,8	4,2	159,4
81,8	4,2	201,3

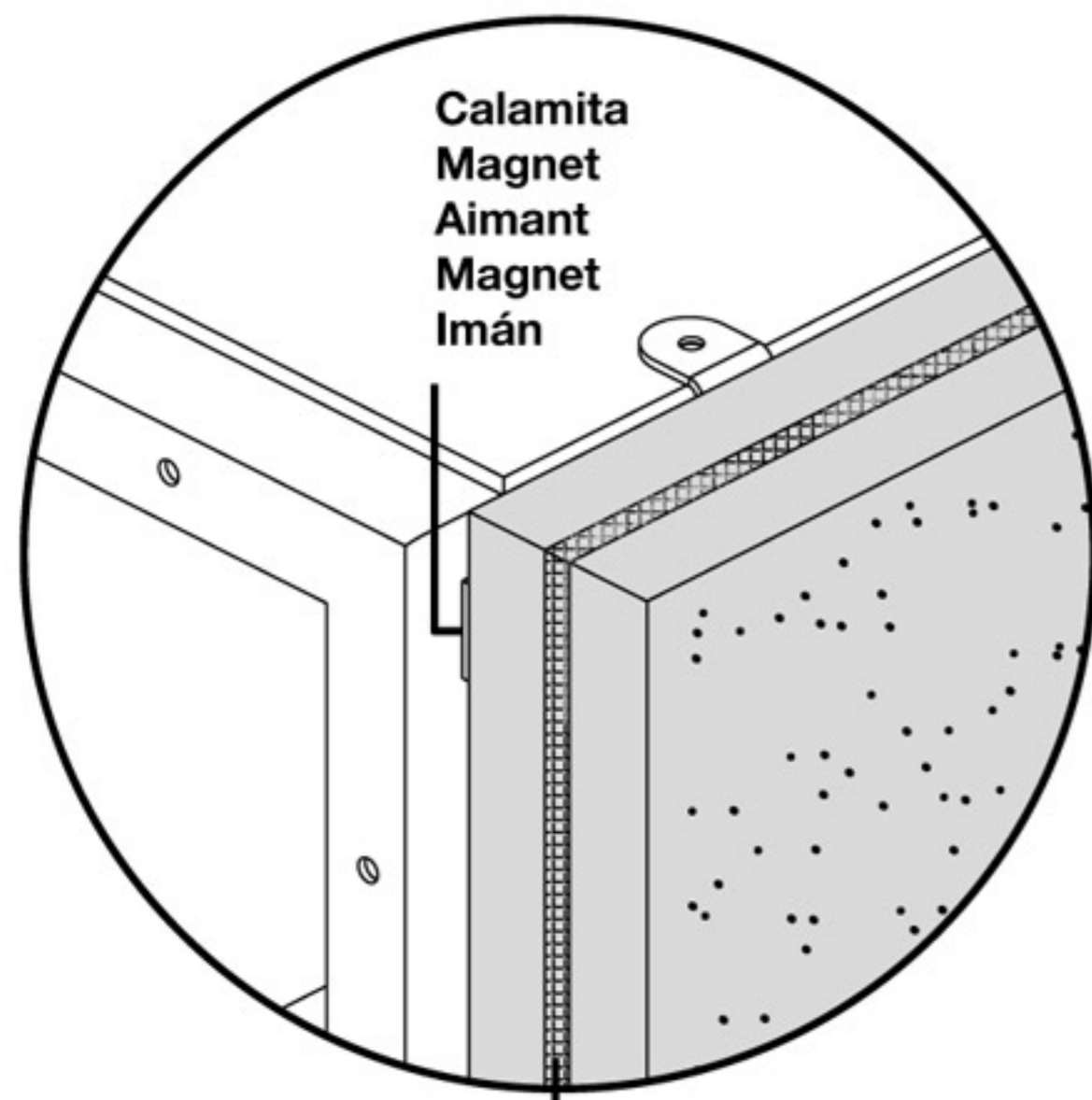

Calamita
Magnet
Aimant
Magnet
Imán

Cordoncino
Cord
Cordon
Schnurkante
Cordon

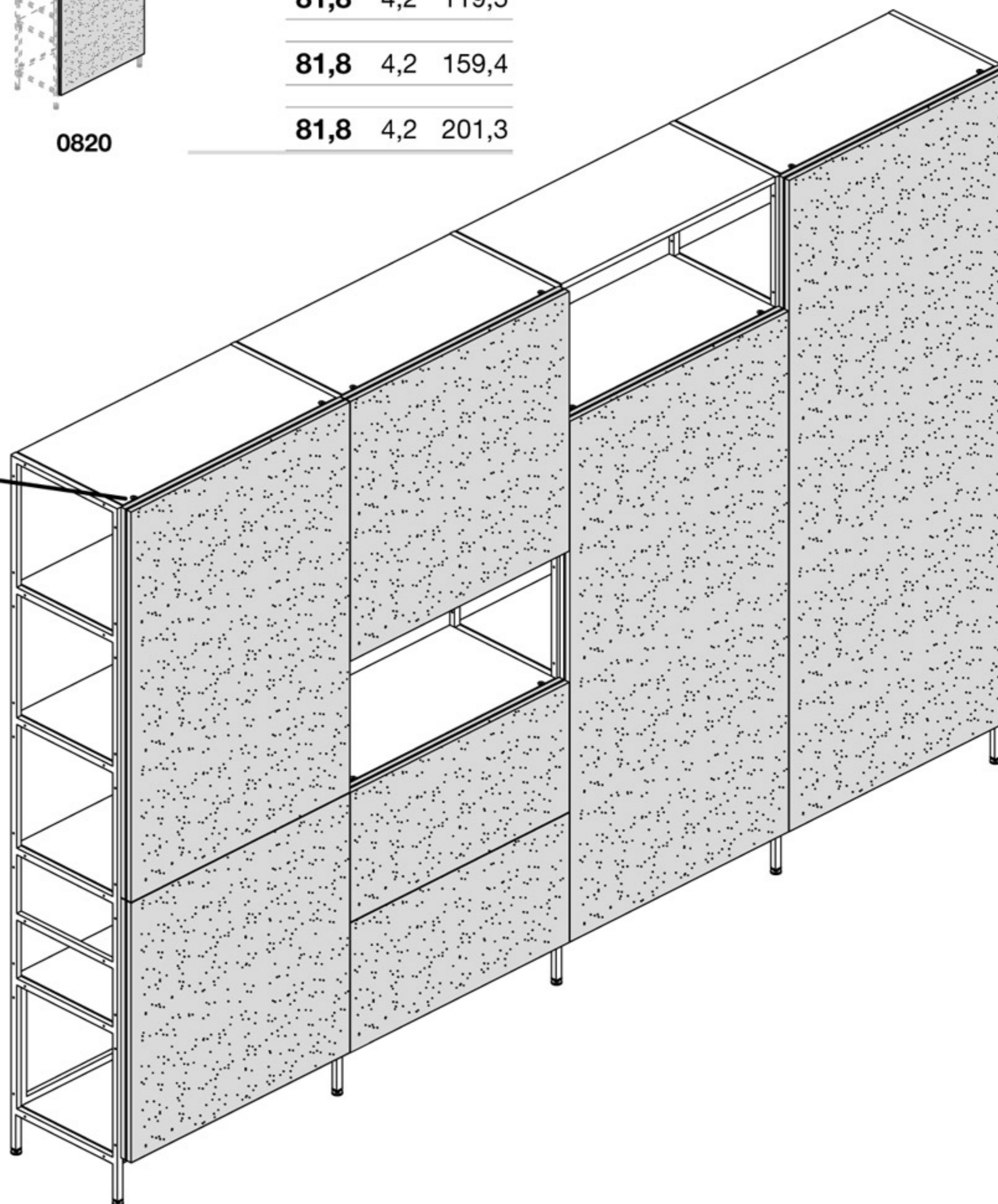

concerto

oberfläche und farben

metallgestelle

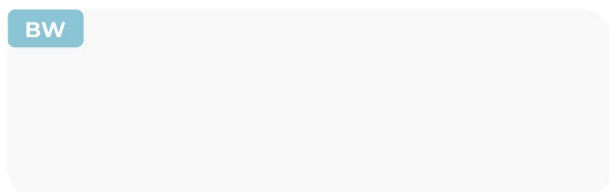
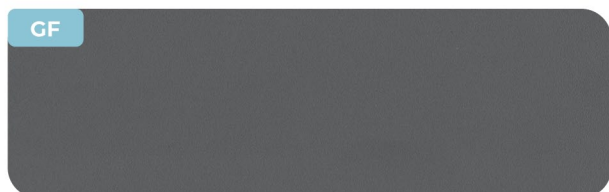
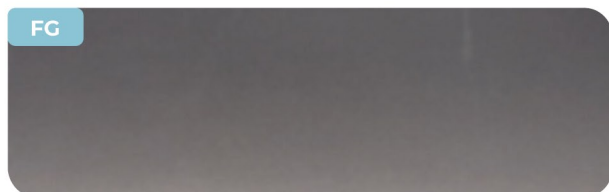

FG: La finitura ferro grezzo "FG" risalta la natura "industriale" del metallo grazie ad un trattamento protettivo trasparente. Differenze di tonalità, abrasioni, striature e saldature sono tipici della materia prima stessa e delle successive lavorazioni e sono tra gli elementi caratterizzanti del prodotto e per questo non contestabili.

FG: The raw steel finish "FG" emphasizes the "industrial" nature of the metal thanks to a transparent protective treatment. Differences in shades, abrasions, stripes and welds are typical of the raw material and subsequent processes, and are among the characteristic elements of the product, therefore not claimable.

FG: La finition en métal brut "FG" démarque la nature "industrielle" du Métal grâce à un traitement avec une protection transparent. Les différences dans les nuances, les abrasions et les soudures sont typiques de la matière première et des ultérieures process de production et font partie des éléments caractéristiques du produit et donc non contestables.

FG: Das rohes Metall-Finish "FG" sticht besonders hervor der "Industriellen" Natur der Metall durch einer Transparenten Schutz Behandlung. Unterschiede in Farbton, Abrieb, Streifen und Schweissungen sind typisch für den Rohstoff und die nachfolgenden Prozesse und gehören zu den charakteristischen Elementen des Produkts und daher sind nicht anfechtbar.

FG: El acabado de hierro bruto "FG" destaca la naturaleza "industrial" del Metal gracias a un tratamiento protector transparente. Las diferencias en los tonos, abrasiones, rayas y soldaduras son típicas de la materia prima y los procesos posteriores y se encuentran entre los elementos característicos del producto y, por lo tanto, es indiscutible.

oberfläche und farben

melaminico, melamine, mélamine,
melamin, melamina



laccato opaco, lacquered matt, lacqué mat,
matt lackiert, lacado mate

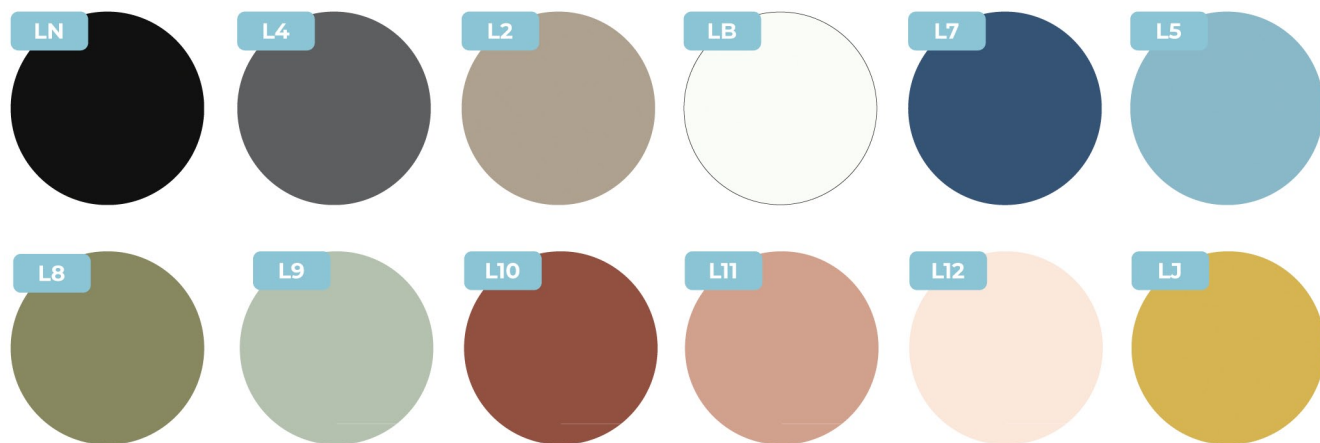

finiture e colori · finishing and colors · finitions et couleurs ·
oberfläche und farben · acabados y colores

tessuto · fabric · tissu · Stoff · tejido

MIRAGE

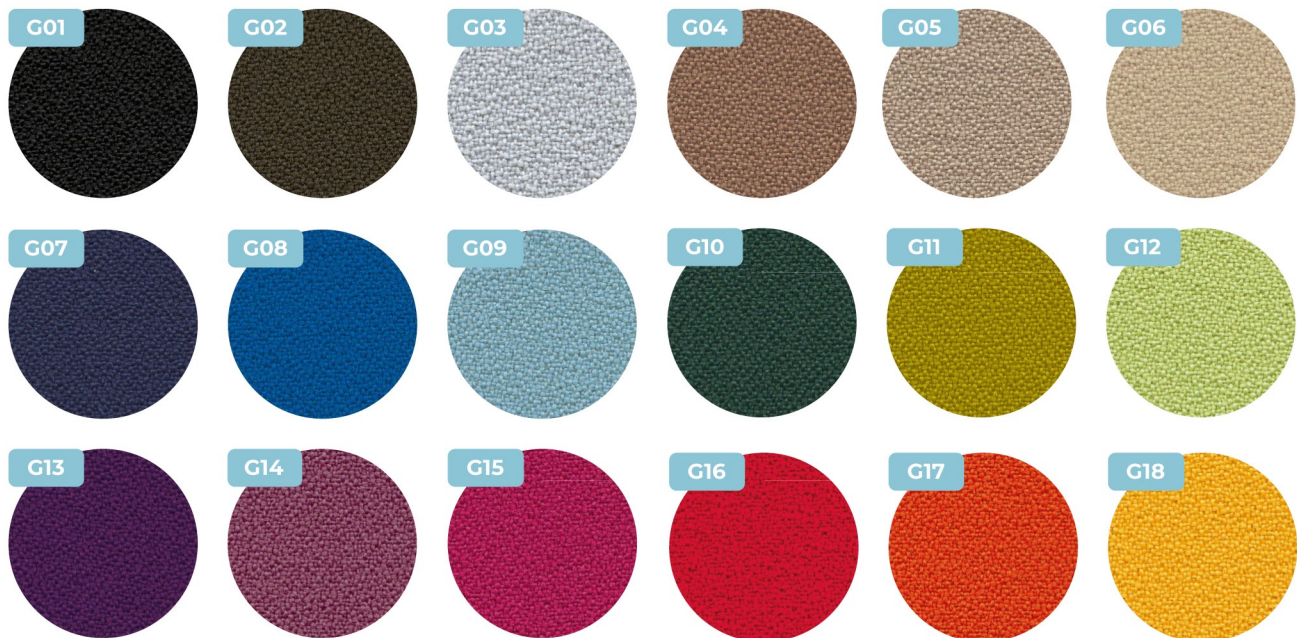

NEMI MELANGE

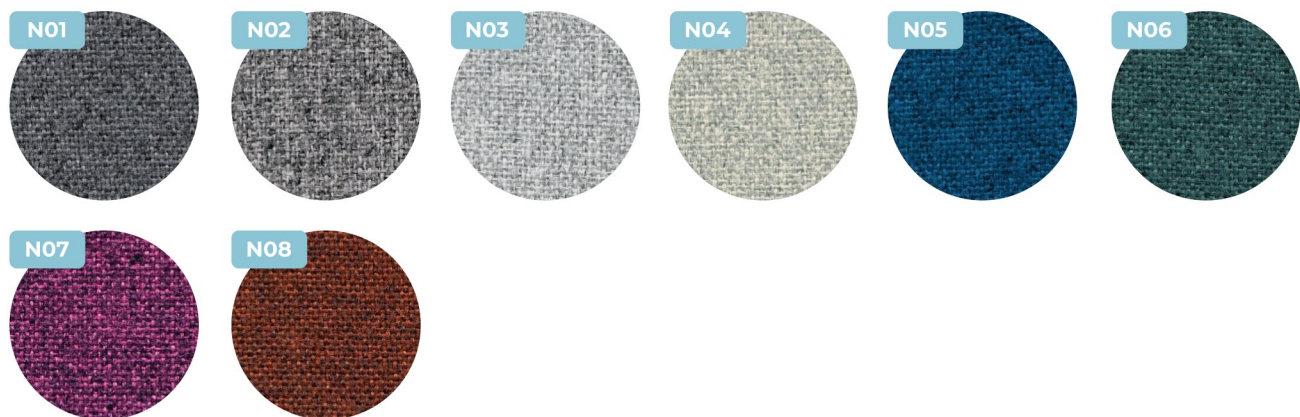

FENICE 🇮🇹

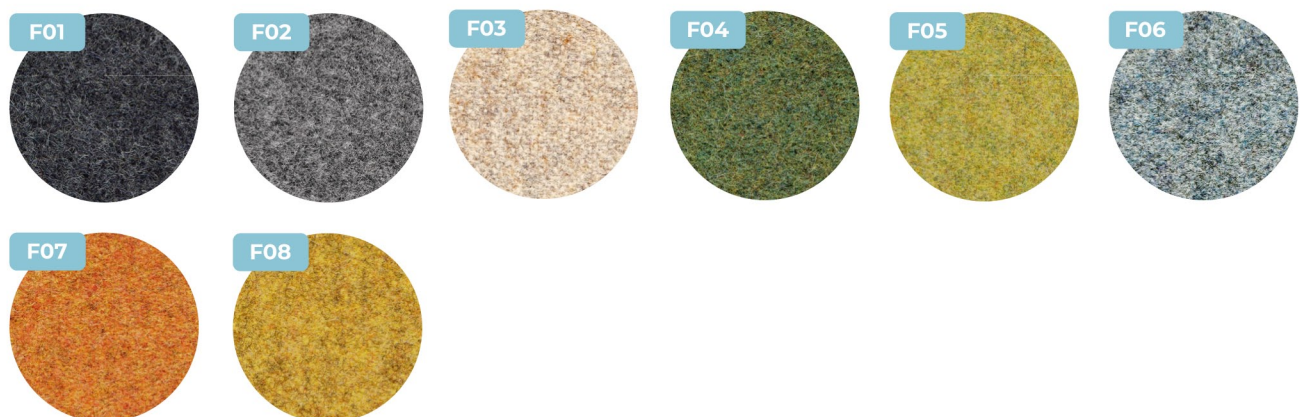

finiture e colori · finishing and colors · finitions et couleurs ·
oberfläche und farben · acabados y colores

CONVERT MEL 4000

